

VITUS 3D Body Scanner

Markus MAURER*
VITRONIC GmbH, Wiesbaden, Germany

<http://dx.doi.org/10.15221/13.187>

Abstract

For more than 15 years VITRONIC has been a world leader in body scanning. VITRONIC develops and manufactures body scanning systems for different areas of applications and to suit different international market.

Keywords: 3d body scanning, 3d body scanner

1. Introduction

VITRONIC started development of this technology in 1994 when VITRONIC agreed to create a prototype body scanner for a local artist. The idea was to take a 3-dimensional scan of a model and to have the rough version of this scan carved into wood. The design of this system was based on technology that VITRONIC had been using in different industries in previous years, such as the 3 dimensional measurements of aluminum ingots, and other general machine vision applications which VITRONIC has been selling since its inception in 1984. As the technology developed, VITRONIC was able to improve on the initial design and started selling a finished product in 1997 called VITUS pro. Most customers of VITUS pro have been using this scanner for research and anthropometrical measurements (for instance: BMW, DuPont, MiraLab, TNO).

In 1999 VITRONIC finished the next body scanner development. This development was driven by the demands of the strong new markets for made-to-measure applications. This scanner was a smaller and cheaper body scanner called "VITUS^{smart} LC" smart". The VITUS^{smart} scanner was designed for installation in a fitting room. This concept of single small scanning pillars still provides the basis for the latest body scanners. Today VITRONIC offers two different versions of body scanners to best satisfy the differing requirements of various market segments.

"VITUS^{smart} LC" is the entry-level model and the scanner is dedicated to applications where the requested floor space is crucial, for example, made to measure solutions in the retail environment.

"VITUS^{smart} XXL" is the second body scanner model. The scanning volume of "VITUS^{smart} XXL" complies with DIN EN ISO 20685 ("3-D scanning methodologies for internationally compatible anthropometric databases"). In addition, this scanner is designed to deliver high density data and minimize hidden surfaces during data acquisition.

Today hundreds of VITUS 3D body scanners are used for a large variety of applications.

2. Method and Technical Key Factors

The VITUS 3D Body Scanner utilizes integrated hardware and software components to perform the process of translating surfaces of physical objects into 3D dimensional data. The VITUS 3D Body Scanner uses the light stripe method as the basis for its measurements.

2.1. Light stripe method

The method used by VITUS is the light stripe method. The functional components of one scanning unit of the VITUS scanner are a diode laser with a cylindrical optical system and a matrix camera. The wavelength of the laser is inside the red band of the visible light spectrum. The laser is used to generate a structured illumination line and the camera is used as a sensor to capture an image of the laser in the target area.

* markus.maurer@vitronic.com; +49-611-7152-133; www.vitronic.com

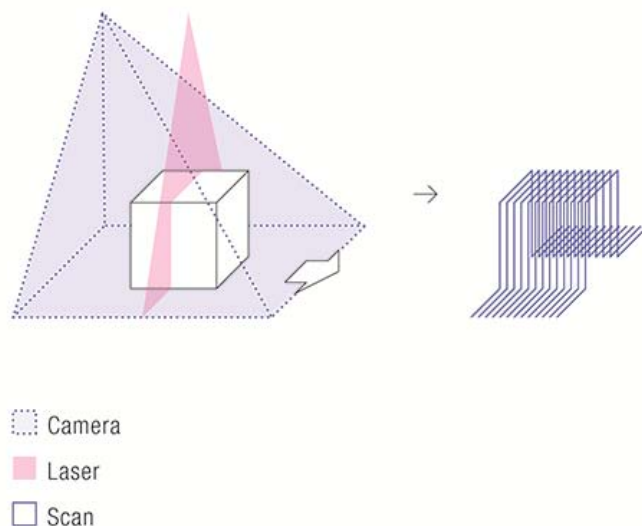

Fig. 1. Light Stripe Method.

The laser projects a line of light that illuminates the region of interest, mounted on a movable device while the object remains stationary. The camera is mounted on the same moveable device at a specific position with a defined angle relative to the laser axis. The camera, or sensor, detects the light reflected from the object. Changes in the shape of the object surface cause the distance from the light point to the sensor to fluctuate.

The sensor then maps this distance onto a plane using x and y components. By means of a calibration procedure the scanning unit is able to translate these distances in mm values. By combining several planes it becomes possible to create a 3-dimensional image of the object.

2.2. Body Scanner Layout

Multiple scanning units are required since it is impossible for one scanning unit to scan an entire body. Each scanning unit can "see" only those parts of the object that are directed towards the camera. Several scanning units therefore have to be combined to scan the object from different directions. Each scanning unit is integrated into a pillar which provides the necessary vertical movement.

A complete system includes in most cases 3 or 4 laser scanning pillars either permanently attached to a hard level floor, or bolted into an aluminum frame; a computer and monitor; an A/D signal converter box; and a calibration tube.

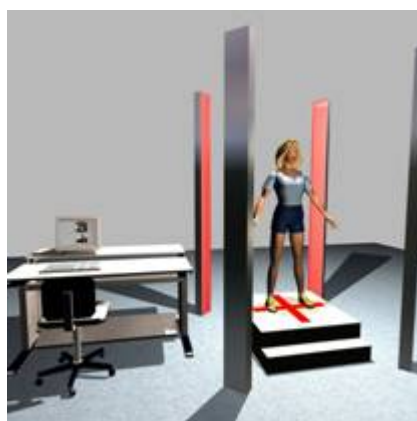

Fig. 2. Complete Body Scanning System [1].

The sensor units are initially arranged at the same horizontal level in each column and move from top to bottom in the columns to scan the entire body. Vertical movement is utilized to ensure that small movements of the body (i.e., postural sway) have a minimal effect on the measurement.

A special calibration procedure ensures that the data delivered by from each of the sensors can be combined into a single coherent three-dimensional model of the scanned object.

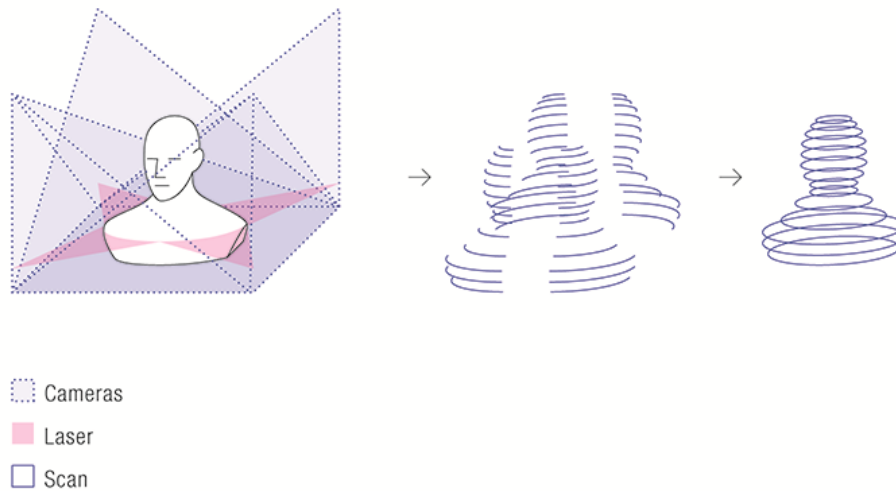

Fig. 3. Combination of different scans in a 3d model by means of calibration.

2.3. Occlusion

After combining the output of several scanning units, there may be parts of the object that cannot be scanned due to occlusion, where the cameras do not “see” them. Assume, for example, that a set of scanning units is arranged around the object and moved linearly from top to bottom during the scanning process. If the light from the lasers forms a horizontal plane and the cameras are mounted above the lasers are directed slightly downward to record images of the laser line on the object, then it is impossible for the cameras to “see” the area below the horizontal laser line (e.g., under the chin of a standing person).

To avoid this situation, each sensor head can optionally be equipped with two cameras. Each sensor head then has one camera located above the laser plane, directed slightly downward and one camera located below the laser plane, directed slightly upwards. This duplication of the measurement area is called double triangulation and enables body areas such as the lower side of a chin to be scanned. Even when a body scanner employs double triangulation, there will still be some parts of an object where occlusion can occur and therefore may not be completely reconstructed.

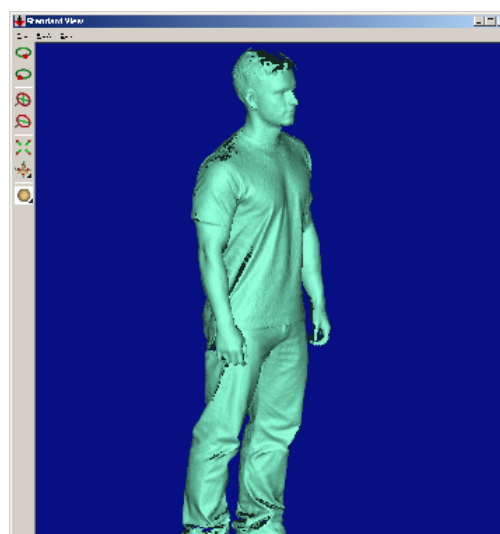

Fig.4. Occlusion of a body scan (e.g. wrinkles of the t-shirt).

Although there is always the possibility to use software algorithms to try to reconstruct these gaps in the scanned data, one of the main goals for the layout of the VITUS body scanners was to find a set up where these occluded areas were minimized in the standard measurement positions.

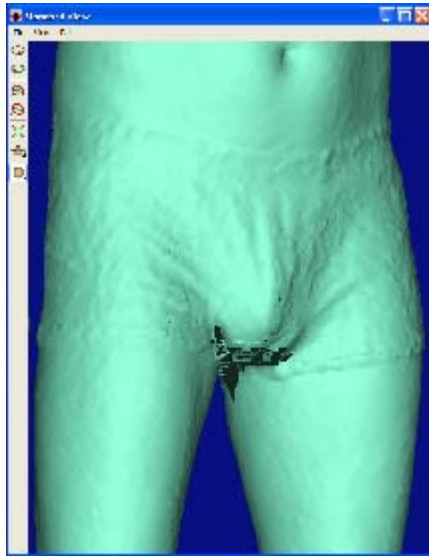

Fig. 5. Occluded areas in the row scan data.

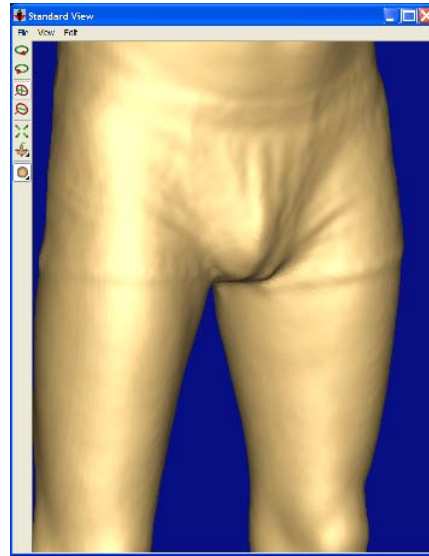

Fig. 6 Reconstructed 3d model by software.

2.4. Different Surface Colors

As the measurement method is an optical one, all visible objects in the measurement area are included in the measurement result. However, if the surface is highly reflective or extremely dark, this could cause gaps in the signal and therefore degrade the result.

In general the light stripe method as deployed by the VITUS scanners is a very robust method and highly suitable for the task, because lasers of a specific wavelength are used to produce the light stripe. In addition the VITUS body scanners use a scanning unit with a very wide dynamic range so that different reflection intensities can be accurately detected.

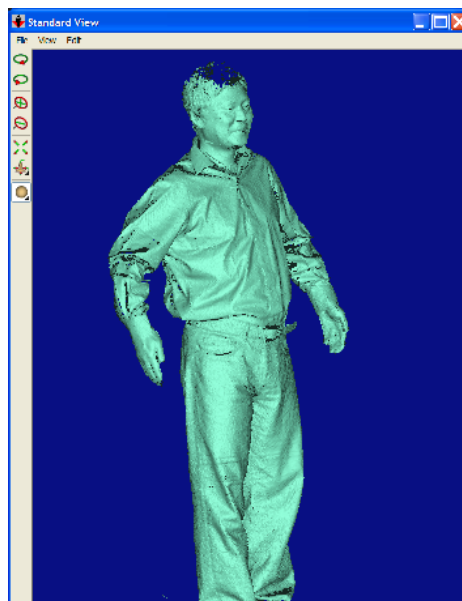

Fig.7. Scan of business man dressed in white shirt and black trousers

2.5. Grey level Texture

For some measurement applications it is beneficial to obtain the texture of the scanned point or surface area in addition to the 3d surface point spatial information (i.e. X,Y,Z value). This can be used for marker detection. The VITUS body scanners can therefore optionally provide grey level information of each scanned surface point.

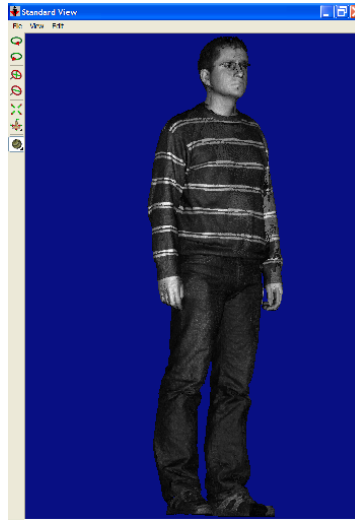

Fig.8. Grey level Scan

3. Cooperation with Human Solutions

VITRONIC entered into a partnership with "Human Solutions" in the early stages of the VITUS product family. Since 1999 "Human Solutions" and VITRONIC have been cooperation partners. As an integrated solution partner, Human Solutions develops innovative solutions for customized clothing, size determination and anthropometrical measurements.

Today Human Solutions has extensive experience in this market. With more than 300 installations, Human Solutions is a worldwide leader in this market. Their solutions are based on VITUS body scanners (VITUS^{smart} LC and VITUS^{smart} XXL) for measurement of the customers.



Fig.9. Typical application for measurement of the human body [1]

4. VITUS in the field of medicine research

4.1. VITUS proofed to meet medicine's needs in terms of precision

In medicine VITUS has been used so far chiefly in the field of research. Faculties specialized in sports medicine; biomechanics and orthopedics have been conducting studies with VITRONICs scanner technology. Orthopedists for example are interested in deducing the spinal shape of an individual based on the 3D surface scan of VITUS. Sports medicines on the other hand are interested in tracking body mass of athletics in order to develop customized training plans. They all opted for VITRONICs 3D scanners because the measurements taken by VITUS fulfill the statistical quality requirements of reproducibility, validity and objectivity. The quality of VITUS measurements has even been proofed in various research papers.

4.2. Case study: VITUS tracks body mass of athletic crossing the Atacama Desert in Chile

One of the universities using VITUS as research device is the "German University of Sports" in Cologne, Germany. The latter institution has recently published the results of an experiment, in which the body mass loss of an athletic crossing the Atacama Desert in Chile has been tracked via VITUS.



To be more precise the experiment consisted of two phases. Phase one was the preparation phase where the researchers have been running tests with the athlete in the university's laboratories, in order to predict the amount of energy needed for crossing the Atacama Desert. Once they anticipated the total amount of energy needed they tried to compute the probable loss of body mass given a specific intake of energy per day that was inferior to the daily energy expenditure. It was of paramount importance to ensure that the loss of body mass would not reach a critical level which would hamper the athlete's capability to continue his journey. To get realistic data about probable body mass loss given the daily energy expenditure and the energy intake, the

researchers used VITUS. After exposing the athlete to different environmental conditions in the laboratory they measured the body mass loss with the 3D scanner, using body volume data. The second phase of the experiment consisted of the actual journey. Before and after the journey the athlete's body mass was measured via VITUS to compare in the end predictions of phase one with the outcome of phase two (KOEHLER, K. et al., 2011).

The outcome of the research was that the simulation of physiological demands can be a valuable contribution to the scientific support of extreme exercise. Individual predictions of energy expenditure can be helpful in the preparation of expeditions, especially when food intake is limited. The data gathered in the experiment indicated that predictions proofed to be correct (KOEHLER, K. et al., 2011).

5. VITUS II: New body scanner version in development

Customer needs develop and become more demanding over time. In the context of 3D body scanning this means more resolution in terms of points per cm² as well as the capability to capture color textures. Moreover standard software packages are not enough to satisfy the specific needs of the different market segments.

VITRONIC therefore decided to take its body scanning technology to the next level, thereby following the market trend. At the end of the second quarter 2014 a new version of VITUS will be launched. It will provide its customers with twice the resolution in terms of points per cm². Moreover it will capture also color textures. In addition to that software packages will be launched that suit for example the need of 3D print stores.



Fig.8. VITUS II in development

6. VITUS^{smart} body scanners

6.1. VITUS^{smart} XXL



Fig.10. VITUS^{smart} XXL

Table 1. Specification VITUS^{smart} XXL.

Measurement principle	optical triangulation with laser light
Safety	Eye-safe Laser Class 1
Sensor heads	4 dual-camera heads
Measurement range Height Z	2100 mm
Measurement range Depth X	1000 mm
Measurement range Width Y	1200 mm
Accuracy cylindrical tube 110 mm diameter, 2100 mm height constant temperature within the range of 15° - 30°C	Average girth error < 1 mm
Measurement time approx.	12 s
Point density	27 pts/cm ²
Scanner Height Z	2850 mm + Frame 100 mm
Scanner Depth X	2200 mm
Scanner Width Y	2200 mm
Scanner Area	4.84 m ²
Input Voltage	230 V / 50 Hz 115 V / 60 Hz 420 VA

6.2. VITUS^{smart} LC



Fig.11 VITUS^{smart} LC

Table 2. Specification VITUS^{smart} LC.

Measurement principle	optical triangulation with laser light
Safety	Eye-safe Laser Class 1
Sensor heads	3 single-camera heads
Measurement range Height Z	2100 mm
Measurement range (Triangle Base X)	900 mm
Measurement range (Triangle Width Y)	900 mm
Accuracy cylindrical tube 110 mm diameter, 2100 mm height constant temperature within the range of 15° - 30°C	average girth error < 3 mm
Measurement time approx.	12 s
Point density	7 pts/cm ²
Scanner Height	2500 mm + Frame 100 mm
Scanner Base, Side length Triangle	2200 mm
Scanner Area (Triangle)	2.98 m ²
Input Voltage	230 V/50 Hz 115 V/60 Hz 420 VA

References

1. Pictures: Copyright by Human Solutions www.human-solutions.de.
2. Koehler, K. et al., (2011). Case Study: Simulated and Real-Life Energy Expenditure During a 3-Week Expedition. Human Kinetics Inc.